



DEEP SEA ELECTRONICS

FEATURES

- Single set parallel with mains facility with 'soft' no-break return.
- Peak lopping functionality to allow cost savings during high tariff periods.
- Test on load facility allows synchronisation to mains (utility) supply to provide 'no break transfer' and hence no break in power supply to the load.
- Can be used to provide additional supply during times of high load.
- No hidden extras – Supplied as a complete package with governor and AVR interface modules
- Automatically senses mains (utility) failure and starts the backup generator.
- Multiple alarm channels for generator protection (ie oil pressure, engine temperature, overspeed and more)
- Clear, backlit LCD display to show the status of engine, generator and mains (utility) as well as to annunciate alarm conditions should they occur.
- Compatible with many popular governor and AVR types (ie Woodward, GAC, Cummins, Newage, Mecc Alte, Leroy Somer and many more!)
- P120 and P121 also provide isolation between the engine / alternator and the control panel.
- 25 event shutdown alarm log.
- Integral, configurable starting and stopping timers.
- Configurable inputs and outputs to help meet complex specifications.

The 500 series modules have been designed for **front panel mounting**. The module is fitted into the cut-out with the fixing clips removed. These are then fitted from the rear. Connection is via locking plug and socket connectors.

DESCRIPTION

The Model 557 is an **Automatic Mains Failure Control Module**, with comprehensive instrumentation and **load control features**. The module is used to monitor a mains supply and automatically start and stop the engine. It indicates the operational status and fault conditions, automatically shutting down the engine and indicating engine failure by means of an LCD display, and flashing LED on the front panel.

Selected operational sequences, timers and alarms can be altered by the customer. Alterations to the system are made using the 810 interface and a PC. This interface also provides real time diagnostic facilities.

Operation of the module is via **pushbutton controls** (with security locking facility) mounted on the front panel with STOP/RESET, AUTO, TEST, MANUAL and START functions. The first four pushbuttons feature LED 'selected' indications. Further pushbuttons provide MUTE/LAMP TEST, LCD PAGE and DISPLAY SCROLL functions.

The module features 32-Bit Microprocessor control and a comprehensive list of timers and pre-configured sequences. User configurable expansion facilities are also provided.

The 557 module provides **metering and alarm facilities** via the LCD display with the following instrumentation displays, accessed via the LCD PAGE and DISPLAY SCROLL push-buttons:

- Generator Volts L1-N, L2-N, L3-N
- Generator Volts L1-L2, L2-L3, L3-L1
- Generator Amps L1,L2,L3
- Generator Frequency Hz
- Generator kVA L1,L2,L3, Total
- Generator kW L1,L2,L3, Total
- Generator pf L1,L2,L3,Average
- Generator kVAh L1,L2,L3, Total
- Generator kWh
- Generator KVAh
- Generator KVAh
- Generator Phase Sequence
- Synchroscope Display
- Mains Volts L1-N, L2-N, L3-N
- Mains Volts L1-L2, L2-L3, L3-L1
- Mains Frequency Hz
- Engine Speed RPM
- Engine Oil Pressure
- Engine Temperature
- Plant battery Volts
- Engine Hours Run
- Number of Start Attempts
- Remaining Time until Maintenance Due

557

AMF AND MAINS PARALLEL CONTROLLER

Issue 2
AM 22/10/03



SPECIFICATION

- DC Supply:**
8V to 35V Continuous.
- Cranking Dropouts:**
Able to survive 0V for 50 mS, providing supply was at least 10V before dropout and supply recovers to 5V. *This is achieved without the need for internal batteries.*
- Max. Operating Current:**
513mA at 12V. 263mA at 24V.
- Max. Standby Current:**
370mA at 12V. 210mA at 24V.
- Alternator Input Range:**
15V(ph-N) to 277V(ph-N) AC (+20%)
- Alternator Input Frequency:**
50Hz - 60Hz at rated engine speed (Minimum: 15V AC Ph-N)
- Magnetic Pick-up Voltage Input Range:**
+/- 0.5V to 70V Peak
- Magnetic Input Frequency:**
10,000Hz (max)
- Mains Sensing Input Range:**
15V(ph-N) to 277V(ph-N) AC (+20%)
- Mains Sensing Input Frequency:**
50Hz - 60 Hz (Minimum: 15V AC Ph-N)
- Start Relay Output:**
16 Amp DC at supply voltage.
- Fuel Relay Output:**
16 Amp DC at supply voltage.
- Auxiliary Relay Outputs:**
5 Amp DC at supply voltage.
- Generator loading Relay Output:**
8 Amp AC 250V.
- Mains loading Relay Output:**
8 Amp AC 250V
- Charge Fail / Excitation Range:**
0V to 35V
- Operating Temperature Range:**
-30°C to +70°C
- Dimensions:**
192mm x 144mm x 138mm
7.6" x 5.7" x 5.5"

Deep Sea Electronics reserve the right to change specification without prior notice.

CASE DIMENSIONS

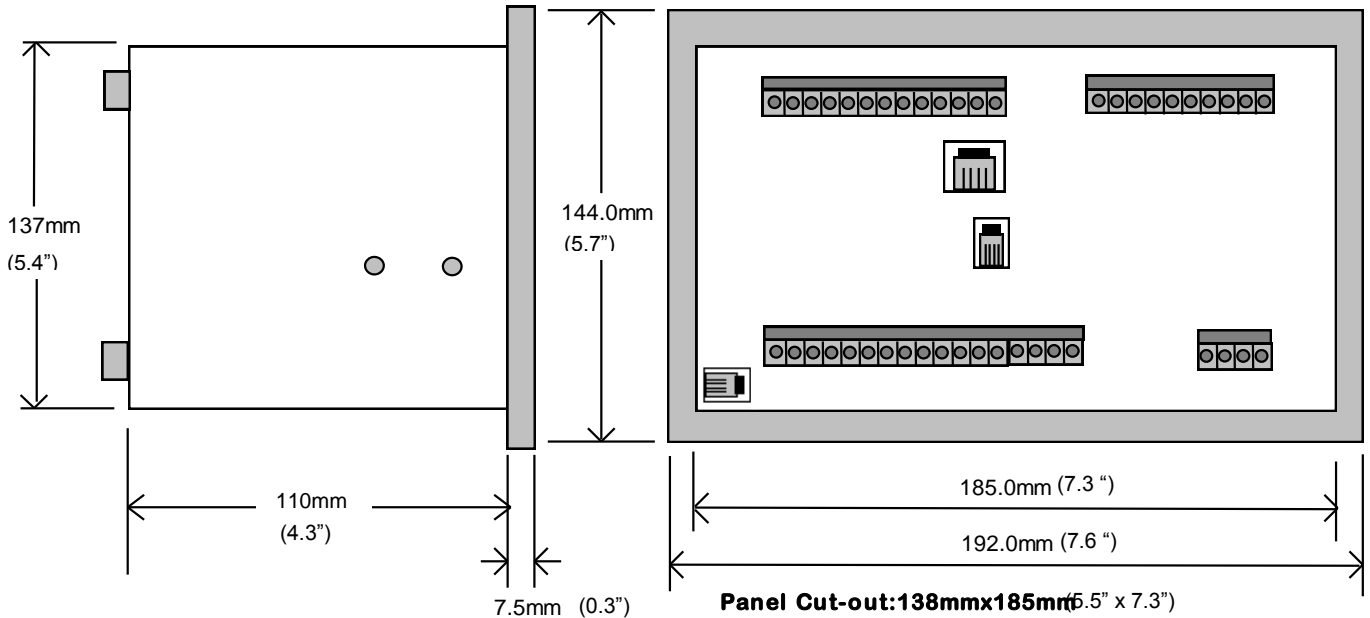

TYPICAL CONNECTIONS

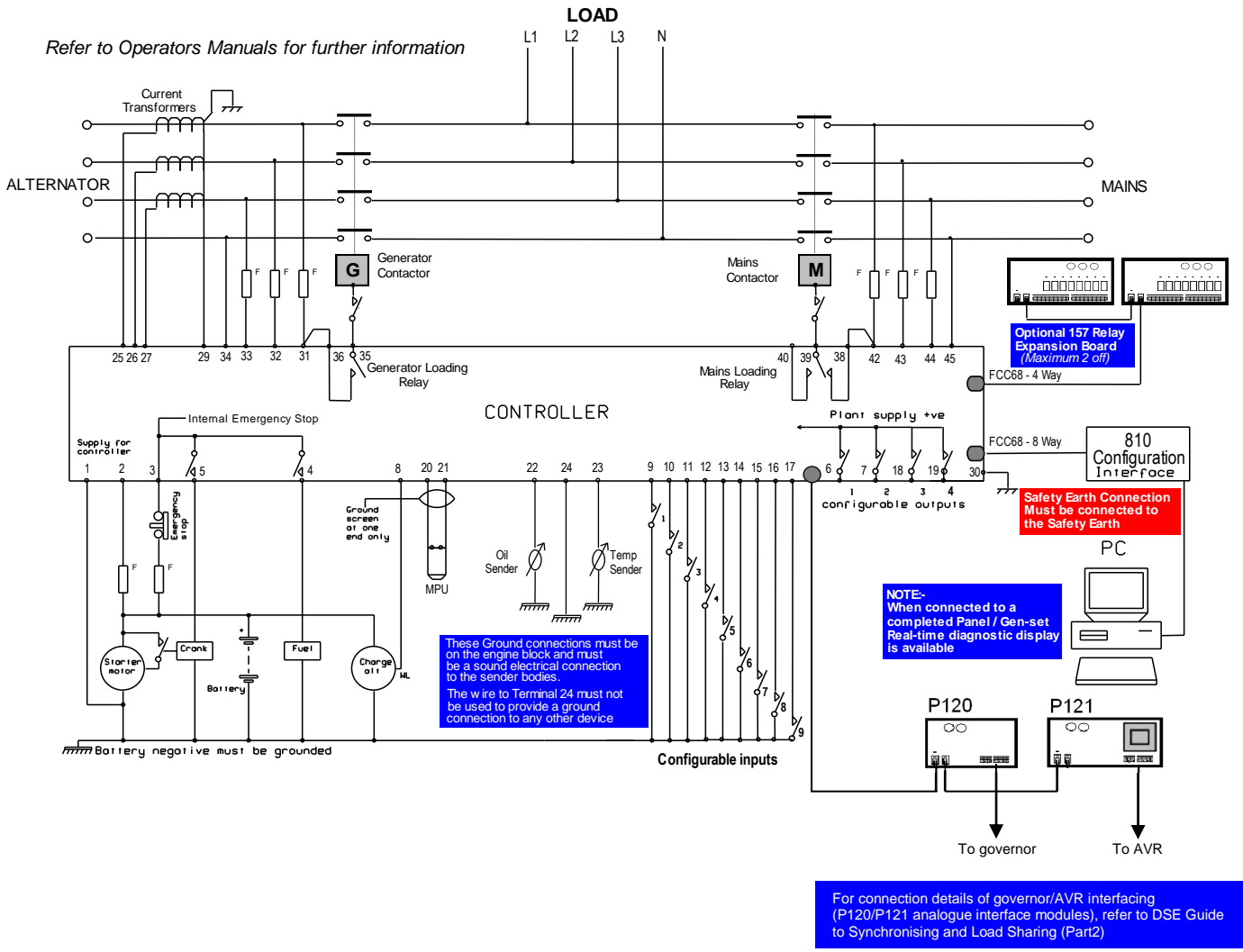

Deep Sea Electronics Plc.
 Highfield House, Hunmanby Industrial Estate,
 North Yorkshire. YO14 0PH. ENGLAND
 Tel +44 (0)1723 890099.
 Fax +44 (0)1723 893303.
 Email - sales@deepseapl.com
 Web - www.deepseapl.com

Deep Sea Electronics Inc.
 5301 E. State St. – Suite 202
 Rockford, Illinois 61108 U.S.A.
 Phone +1 (815) 316-8706
 Fax +1 (815) 316-8708
 Email – dsesales@deepseausa.com
 Web – www.deepseausa.com