



DEEP SEA ELECTRONICS PLC

550

AUTO START
SYNC/LOAD SHARE
MODULE

Issue 6
VH 18/01/02

FEATURES

- Auto sync versions provide automatic voltage and frequency matching with check sync function integrated into the control logic.
- Load share versions provide a dedicated multi-set communications port allowing up to 16 generators to load share, starting/stopping independent sets in the system according to load demand.
- Comprehensive remote communication via optional RS232 port. Provides RS232 Modem link to PC via either PSTN line or GSM network (*with suitable modem*). Uniquely the module supplies DC power to the modem to ensure integrity of link during loss of mains and engine starting. The module can also signal Engineers via their cell phones using the GSM SMS messaging system to advise of system alarms.
- Optional RS485 'Modbus' output - using industry standard communication protocol allows full system integration into new and existing building management and control schemes.
- 'Basic' module provides a number of control and monitoring features with expansion capabilities to meet with more demanding specifications. The ideal choice where a remote communications control system is specified (*when used with one of the comms output options above*).
- 'Enhanced power measurement' module provides all the functions of 'Basic' unit but also includes full power monitoring instrumentation (detailed right).

The 500 series modules have been designed for **front panel mounting**. The module is fitted into the cut-out with the fixing clips removed. These are then fitted from the rear. Connection is via locking plug and socket connectors.

DESCRIPTION

The Model 550 is an **Automatic Engine Control Module**. The module is used to automatically start and stop the engine, indicating the operational status and fault conditions by means of an LCD display and a flashing LED on the front panel. Selected operational sequences, timers and alarms can be altered by the user. Alterations to the system are made using the 810 interface and a PC. This interface also provides real time diagnostic facilities.

It is also possible to monitor the operation of the system either locally or remotely. (*Optional: Remote Communications output versions only*). Access to the module is protected by PIN number to prevent unauthorised access.

Operation of the module is via **pushbutton controls** (with security locking facility) mounted on the front panel with STOP/RESET, AUTO, MANUAL and START pushbuttons. The first three pushbuttons feature LED 'selected' indications. Further pushbuttons provide MUTE/LAMP TEST, LCD PAGE and DISPLAY SCROLL functions.

The module features **32-Bit Microprocessor** control and a comprehensive list of timers and pre-configured sequences. This allows demanding specifications to be achieved. Configurable expansion facilities are also provided.

The 550 module provides **metering and alarm facilities** via the LCD display with the following instrumentation displays, accessed via the LCD PAGE and DISPLAY SCROLL push-buttons:

Generator Volts L1-N, L2-N, L3-N
 Generator Volts L1-L2, L2-L3, L3-L1
 Generator Amps L1,L2,L3
 Generator Frequency Hz
 Engine Speed RPM
 Engine Oil Pressure
 Engine Temperature
 Plant battery Volts
 Engine Hours Run
 Number of Start Attempts
 Remaining time until Maintenance due



Optional, on Power Measurement version only:

Generator kVA L1,L2,L3, Total
 Generator kW L1,L2,L3, Total
 Generator pf L1,L2,L3,Average
 Generator kVAr L1,L2,L3, Total
 Generator KWh
 Generator KVAh
 Generator KVAh
 Generator Phase Sequence
 Synchroscope Display with check sync

The instrumentation displays are supplemented further by **LCD display pages** covering operating status and alarms. The selected page is displayed along with an LED tell-tale:

Status Page, Alarm Page, Engine Instruments Page, Generator Instruments Page, Event Log Page

LED indication is provided for Alarm present.

4 uncommitted LED's allow the user to configure the module to provide other status indications from either internal states or from external digital inputs.

The module accepts the following **digital inputs**:

Emergency Stop Input - A N/C DC positive input
 Fully configurable warning or shutdown inputs

Description continues overleaf...

DESCRIPTION

Continued

With the exception of the Emergency Stop Input, these are configurable to be either N/C or N/O contacts connected to the -Ve DC. The nine fully configurable auxiliary inputs can be selected to be indication, warning or shutdown inputs either immediate or held off during start up to allow for use as protection expansion inputs. Alternatively they may be configured to control extra functions such as manual load switching, Lamp Test or Remote Start input, Generator Start signal and many others - refer to appropriate manuals for details.

Engine **analogue inputs** are provided for Oil Pressure and Engine Temperature. These connect to conventional engine mounted resistive sender units (such as VDO or Datcom Type) to provide accurate monitoring and protection facilities. Alternatively they can be configured to interface with digital switch type inputs for Low Oil Pressure and High Engine Temperature shutdowns.

Relay outputs are provided for Fuel Solenoid Output, Start Output and four configurable outputs. The configurable relay functions can be selected from a range of 100+ different functions, conditions or alarms. The relays supply positive plant supply out. Additional output relays can be added by means of up to two 157 Relay Expansion Modules. A total of 20 outputs are available with full expansion of the 550 Module. This allows the module system to be incorporated into existing telemetry or Building Management Schemes via Volt-free contacts. Refer to appropriate manuals for details.

Multiple alarm channels are provided to monitor the following:

- Under/Over Generator Volts
- Over-current
- Under/Over Generator Frequency
- Under/Overspeed
- Charge Fail
- Emergency Stop
- Low oil pressure
- High engine temperature
- Fail to Start
- Low/High DC Battery Volts
- Fail to come to rest

- Generator Short Circuit Protection
- Reverse Power (*'Power Measurement' Version only*)
- Generator Phase rotation error (*'PM' Version only*)
- Earth Fault Protection (*'PM' Version only*)
- Loss of speed sensing signal
- Fail to Sync (PM Version only)
- MPU Open circuit failure along with any configurable input alarms as selected. Alarms are indicated by an LCD Message, LED illumination and Audible Alarm.

SPECIFICATION

DC Supply:

8 to 35 V Continuous.

Cranking Dropouts:

Able to survive 0 V for 50 mS, providing supply was at least 10 V before dropout and supply recovers to 5V. *This is achieved without the need for internal batteries.*

Max. Operating Current:

513mA at 12 V. 263 mA at 24 V.

Max. Standby Current:

370 mA at 12 V. 210 mA at 24 V.

Alternator Input Range:

15V(ph-N) to 277V(ph-N) AC (+20%)

Alternator Input Frequency:

50 - 60 Hz at rated engine speed (Minimum: 15V AC Ph-N)

Magnetic Pick-up Voltage Input

Range:

+/- 0.5 V to 70 V Peak

Magnetic Input Frequency: 10,000 Hz

(max)

Start Relay Output:

16 Amp DC at supply voltage.

Fuel Relay Output:

16 Amp DC at supply voltage.

Auxiliary Relay Outputs:

5 Amp DC at supply voltage.

Dimensions:

192 X 144 X 138

Charge Fail / Excitation Range:

0 V to 35 V

Operating Temperature Range:

-30 to +70°C

NOTE

An Automatic mains failure version of the 550 is also available (Model 555). This combines all the features of the 550 coupled with built-in mains monitoring and change-over contactor control. Please refer to Deep Sea Electronics for details.

TIMERS AND INPUT FUNCTIONS

- Start delay timer
- Stop delay timer
- Crank/Crank rest timers
- Engage attempt and manual crank limit timers
- Safety on delay timer
- Warm-up timer
- Cooling timer
- Energise to stop hold timer
- Pre-heat timer / Pre-heat bypass timer
- Smoke limiting control timers
- Fail to come to rest timer
- Over-speed overshoot timer
- Breaker pulse control timers
- DC Battery alarm delay timers
- Sync/Fail to Sync timer (*PM Versions Only*)

INTERFACE OPTIONS

P120 Specification

DC Supply:

8-35V DC continuous. Reverse polarity protected

Max. Operating Current:

75mA at 12V, 45mA at 24V

Minimum Load Impedance:

1000 Ω

P121 Specification

AC Input Voltage range:

152 V (ph-N) to 305V (ph-N) AC (+20%)

AC Input Frequency:

50 to 75 Hz at rated engine speed

Minimum Load Impedance:

1000 Ω

P122 Specification

DC Supply:

8-35V DC continuous. Reverse polarity protected

Max. Operating Current:

250mA at 12V, 125mA at 24V

Output Rating:

0.6W

TELEMETRY

The 550 module provides the user with the option of full telemetry facilities via the optional communications software. The module can be either connected to the PC using the 810 interface or via a suitable modem (*Optional: Remote Communications output version only - RS232 or RS485 available*).

The PC software is MS-Windows™ based and allows the operator to control the module from a remote location.

The remote operator can also view the instrumentation, Alarm and Data log details, and the relay and input status.

All access is password controlled so unauthorised operators cannot log onto the system.

Additionally, in the event of the module detecting an alarm condition, it will initiate a modem dial out to the host PC to inform the remote operator of the problem, giving identification of the module followed by the alarm event and the time and date of occurrence (*Optional: Remote Communications output version only*).

If using a GSM modem, the module is also able to send text messages to a GSM cell phone to indicate genset, site and alarm condition.

EVENT CAPTURE

The standard module features **event capture facilities**, this records the last 25 shutdown alarms allowing the operator to view the recent operating history of the module to assist in fault finding, etc.



Event Log:-

19 Apr2000
14:34:14

CONFIGURATION

PC based configuration software allows for fast, simple and secure configuration of module parameters. Utilising the P810 interface to provide a safe isolated link to the PC, changes can easily be made to the system by authorised personnel. Access is PIN number protected.

Complex configurations can be saved and loaded from disk or output to a printer for reference. Diagnostic facilities allow for fault finding and monitoring during test and installation.

BUILT-IN FUNCTIONS

- Alternator Under/Over Volts Warning/Shutdown
- Alternator Under/Over Freq. Warning/Shutdown
- Under/Over Speed Warning/Shutdown
- Low Oil Pressure Warning/Shutdown
- High Engine Temp Warning/Shutdown
- High/Low Battery Volts Warning
- Over-current Warning/Electrical Trip/Shutdown
- Reverse Power Electrical Trip/Shutdown (Option)
- Phase sequence Electrical Trip/Shutdown (Option)
- Earth Fault Shutdown (Option)
- Short Circuit Fault Electrical Trip/Shutdown
- Adjustable crank cycle/attempts
- Maintenance due alarm function
- External remote start input (On load/Off load/on load demand)
- Built in Exercise Scheduler
- Magnetic Pick-up or Alternator speed monitoring
- Synchroscope with auto sync output (Option)
- Event Logging of Shutdown Alarms
- Full Remote Control and Telemetry (Option)
- Graphic LCD Display for true Multi-lingual use
- Multi-lingual capability - 4 default Languages.
- 9 Digital inputs - Fully user configurable
- 4 Configurable relay outputs (100+ Control functions)
- LCD Back-lighting for low light level operation
- System lock input
- Load switching control push-button inputs
- Security via PIN Number restricted access
- SMS messaging capability with suitable GSM Modem
- Limited configuration from front panel - including user language selection

SYNCHRONISING AND LOAD SHARING OPTIONS

- Sync check
- Governor/engine speed control
- AVR/voltage control
- Dead bus sensing
- Synchroscope
- kW Load share for multiple sets
- Multi-set load demand operation

Optional:

- P120 analogue governor interface
- P121 analogue AVR interface
- P122 Digital resistance interface

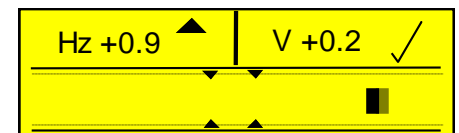

ENVIRONMENTAL TESTING STANDARDS

Electromagnetic Compatibility

BS EN 50081-2 EMC Emission Standard for the Industrial Environment

BS EN 50082-2 EMC Immunity Standard for the Industrial Environment

Vibration

BS EN 60068-2-6 Ten sweeps (up and back down) at 1 octave/minute in each of the three major axes.

5Hz to 8 Hz @ +/-7.5mm constant displacement.

8Hz to 500 Hz @ 2gn constant acceleration

Temperature

Cold:

BS EN 60068-2-1-to -30° C

Hot:

BS EN 60068-2-2 to 70° C

Humidity

BS EN 2011 part 2.1 93% RH @ 40° C for 48 hours

Shock

BS EN 60068-2-27 Three half sine shocks in each of the three major axes 15gn amplitude. 11mS duration.

Electrical Safety

BS EN 60950 Low Voltage Directive/Safety of information technology equipment, including electrical business equipment.

CASE DIMENSIONS

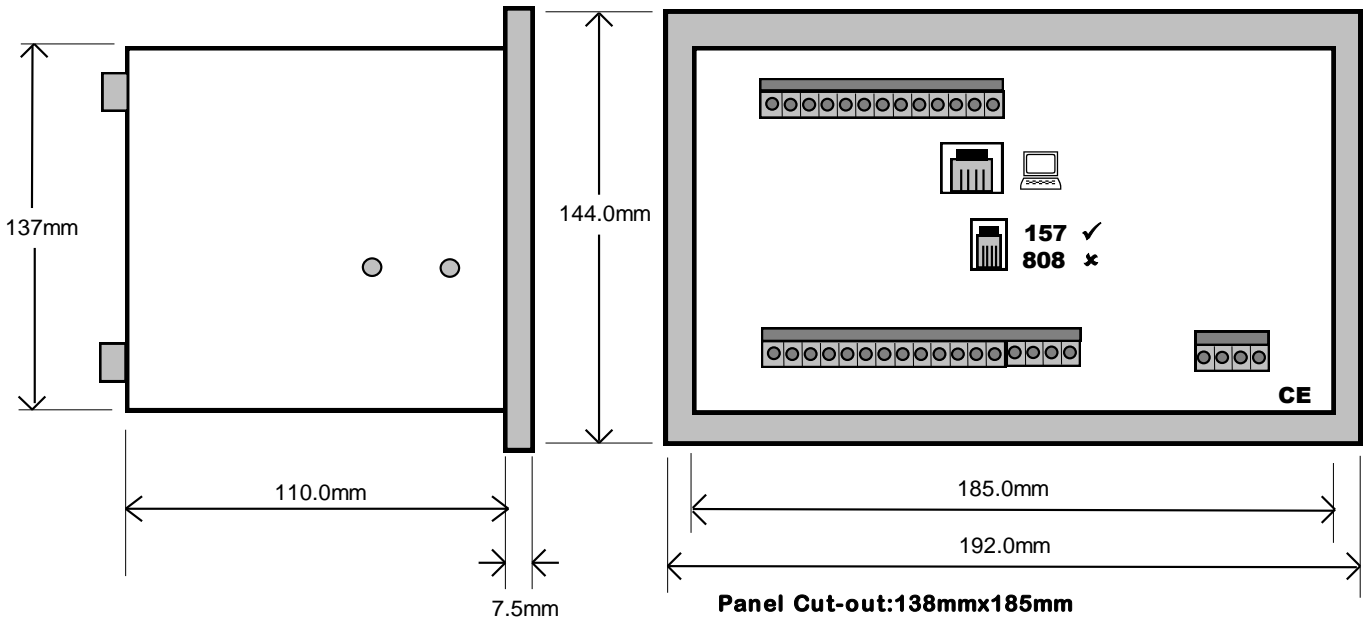

TYPICAL CONNECTIONS

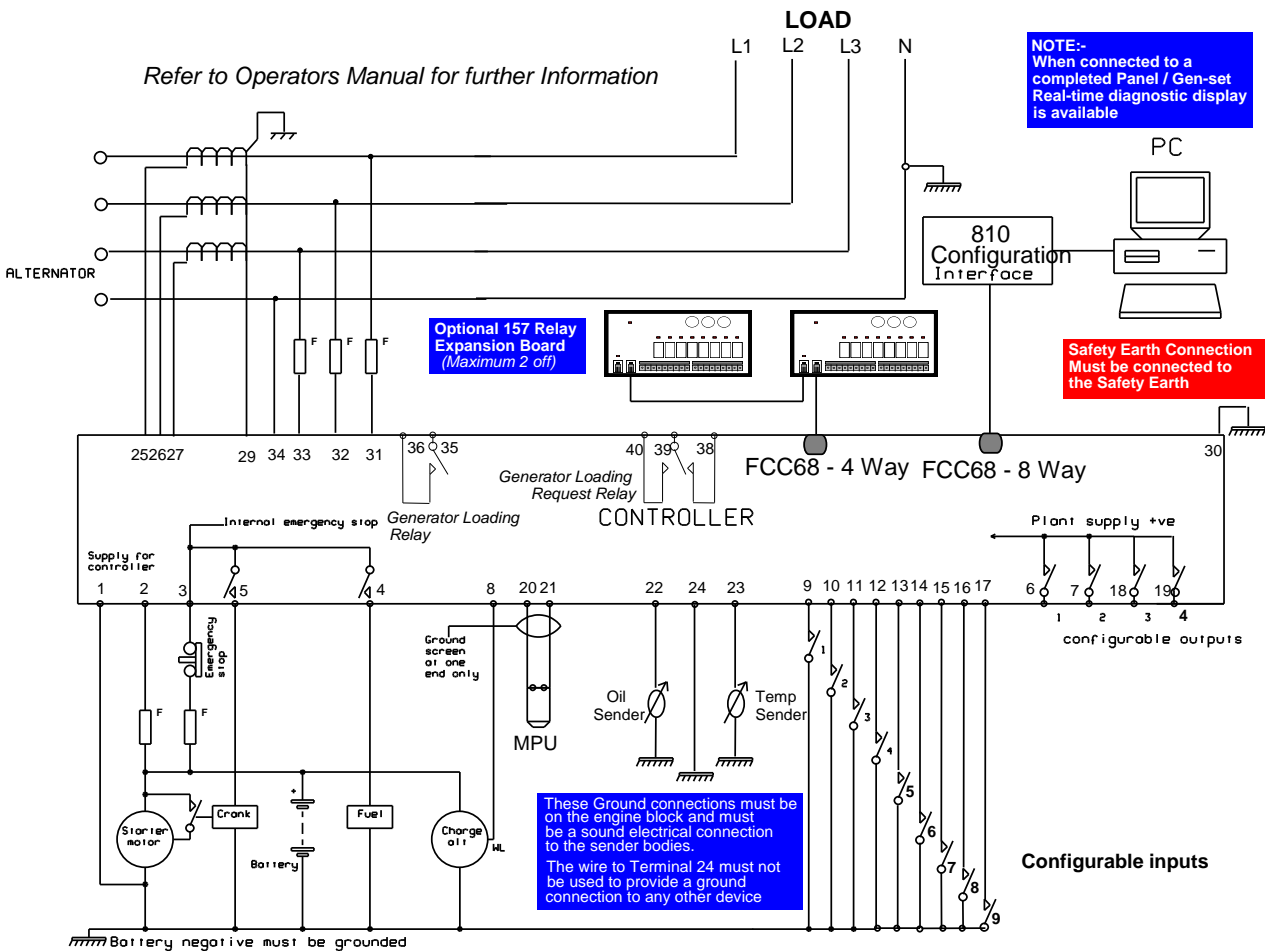

Deep Sea Electronics plc

Highfield House, Hunmanby Industrial Estate, North Yorkshire, YO14 0PH, England
Tel: +44 (0) 1723 890099 Fax: +44 (0) 1723 893303 E-mail sales@deepseapl.com